



Series 37-1 PCB Tainer

WEIGHT

0.37 g/cm (.033 oz./in.)

MATERIALS AND FINISH

HOUSING

Material:

.005-in. (.13-mm) thick
Beryllium Copper per ASTM
B-194 or Stainless Steel per
MIL-S-5059

Finish:

See finish table on opposite
page

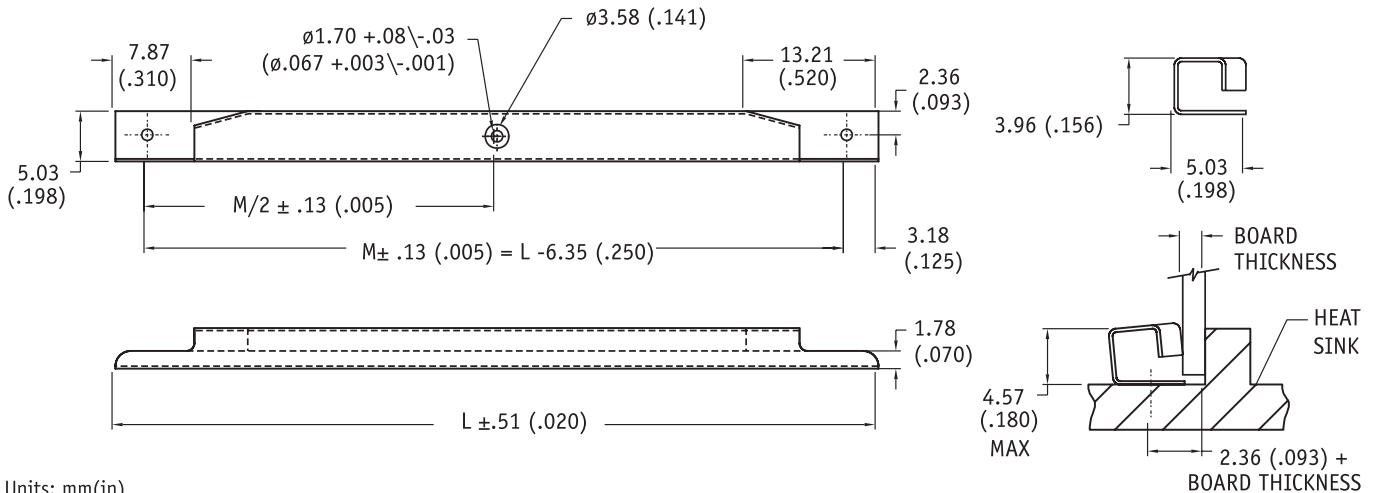
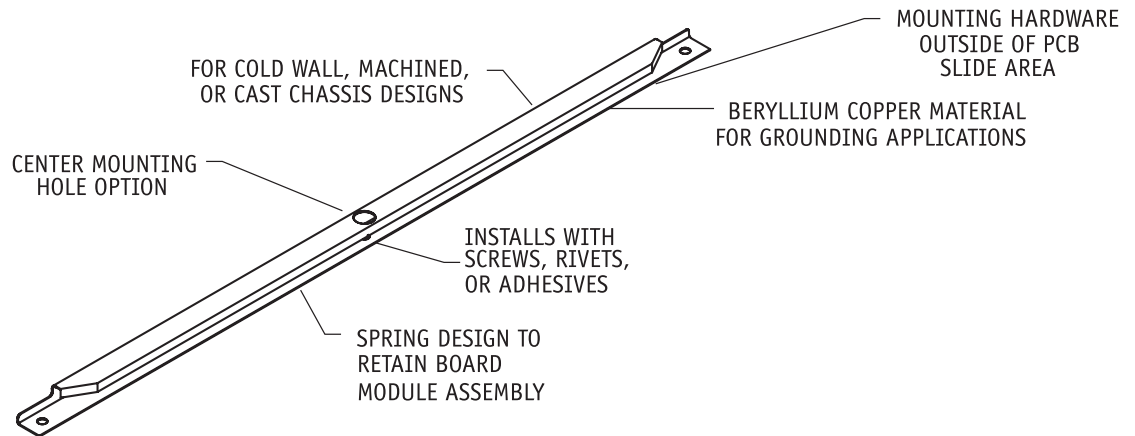

Units: mm(in)
unless specified otherwise,
.xx = ± .25, .x = ± .5
(.xxx = ±.010, .xx = ± .02)

MATERIALS TABLE

CODE LETTER	MATERIAL
B	BERYLLIUM COPPER, 1/4H PER ASTM-B-194
BH	BERYLLIUM COPPER, 1/4HT PER QQ-C-533, HEAT TREATED
CR	STAINLESS STEEL, TYPE 301 COND 1/4 H PER AMS 5517

FINISH TABLE

DASH #	FINISH
[blank]	SILVER PLATE PER QQ-S-365, TYPE III, GRADE A
-1	NONE
-2	EBANOL PER MIL-F-495 FOR BERYLLIUM COPPER PER MIL-C-13924 FOR STEEL
-3	CADMIUM PER QQ-P-416, TYPE 2, CLASS 2
-4	COPPER PLATE PER MIL-C-14550, CLASS 2
-5	GOLD PLATE PER MIL-G-45204, TYPE 1, GLASS 1
-6	NICKEL PLATE PER QQ-N-290, CLASS 1, GRADE G, BRIGHT
-7	ZINC PLATE CLEAR CHROMATE, PER ASTM-B-633, Fe/Zn 8
-8	ZINC PLATE YELLOW CHROMATE, PER ASTM-B-633, Fe/Zn 8

Part Number Code	ZB- 37 C - 1 - B - 10 - 5
Series 37-1 PCB-TAINER	
Center Mounting Hole:	
Center Mounting Hole option: _____ C	
None: _____ [Blank]	
Material	
Beryllium Copper _____ B	
Length	
Length in 12.7 (.50) increments _____ 2 [25.4 (1.00)]	
_____ to 12 [152.4 (6.00)]	
Finish	
Gold Plate _____ 5	
No dash number required for CR material; Stainless steel parts are passivated only.	

Part Number Code examples:

37-1CR-12

Series 37-1 PCB-TAINER, stainless steel, 152.4-mm (6.00-in.) long, passivated

37-1 Series "Length" not available with -2 option