

mit Zwischenring
with Intermediate Ring

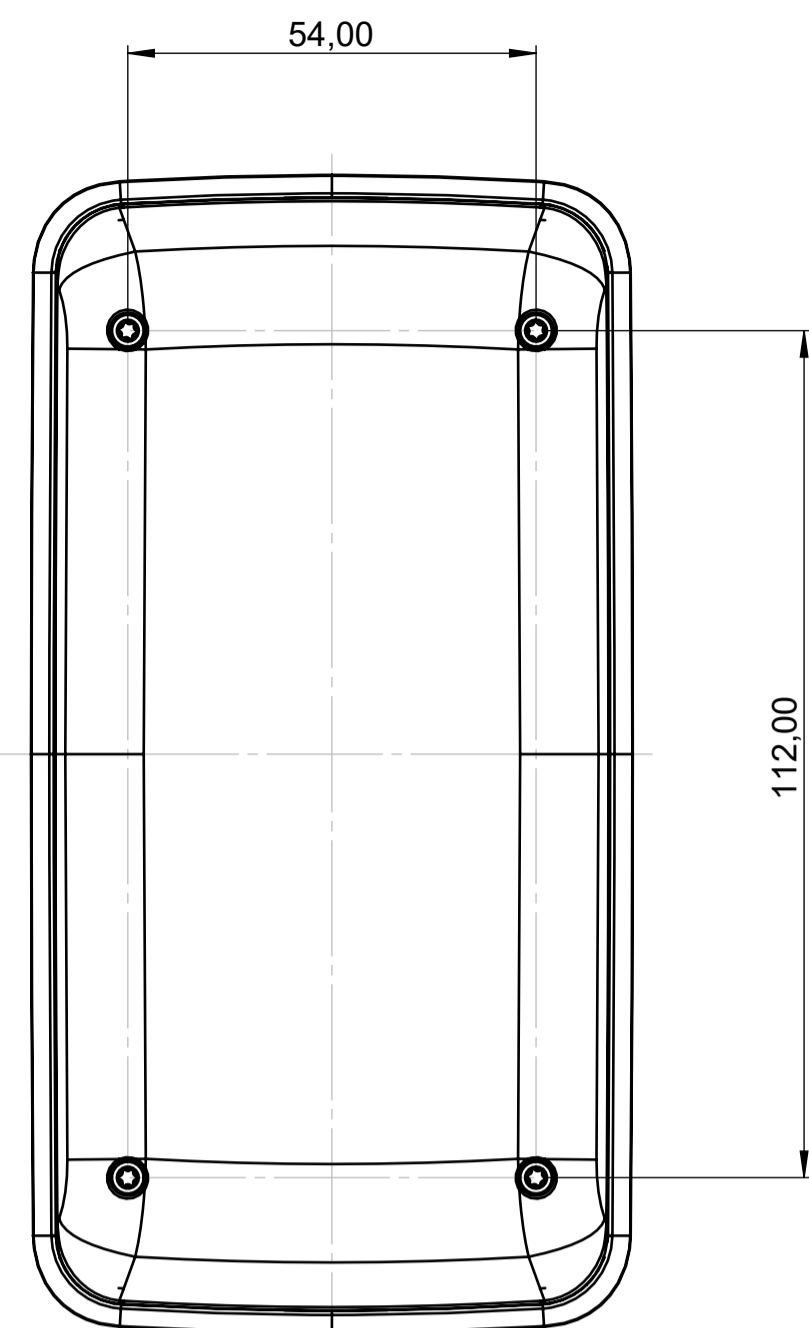

Schnitt A-A

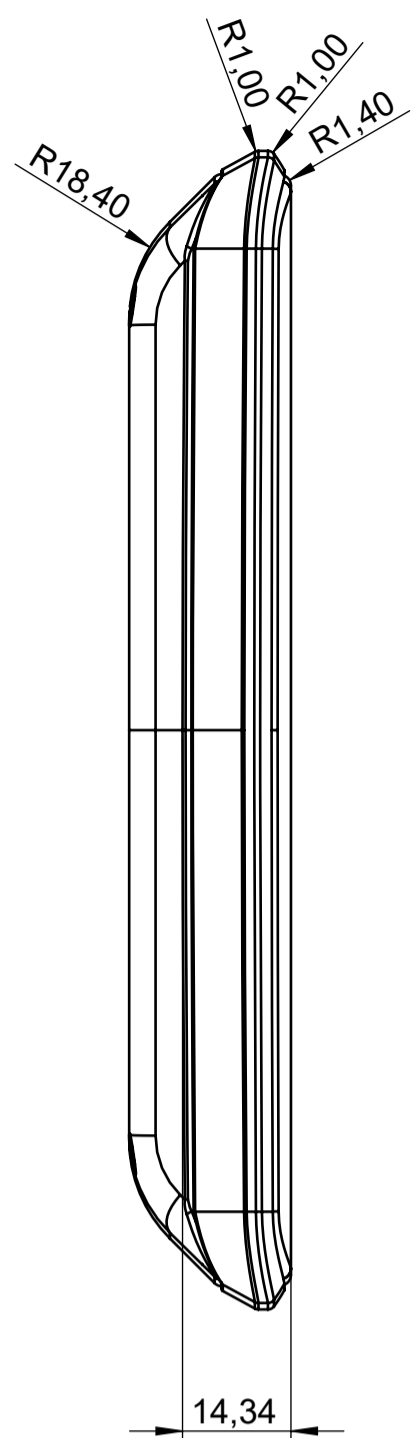
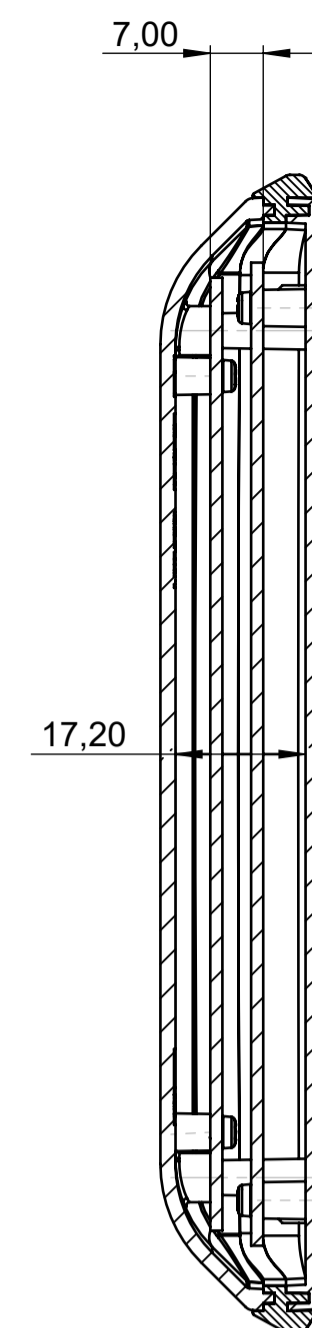

Oberteil
Top Part

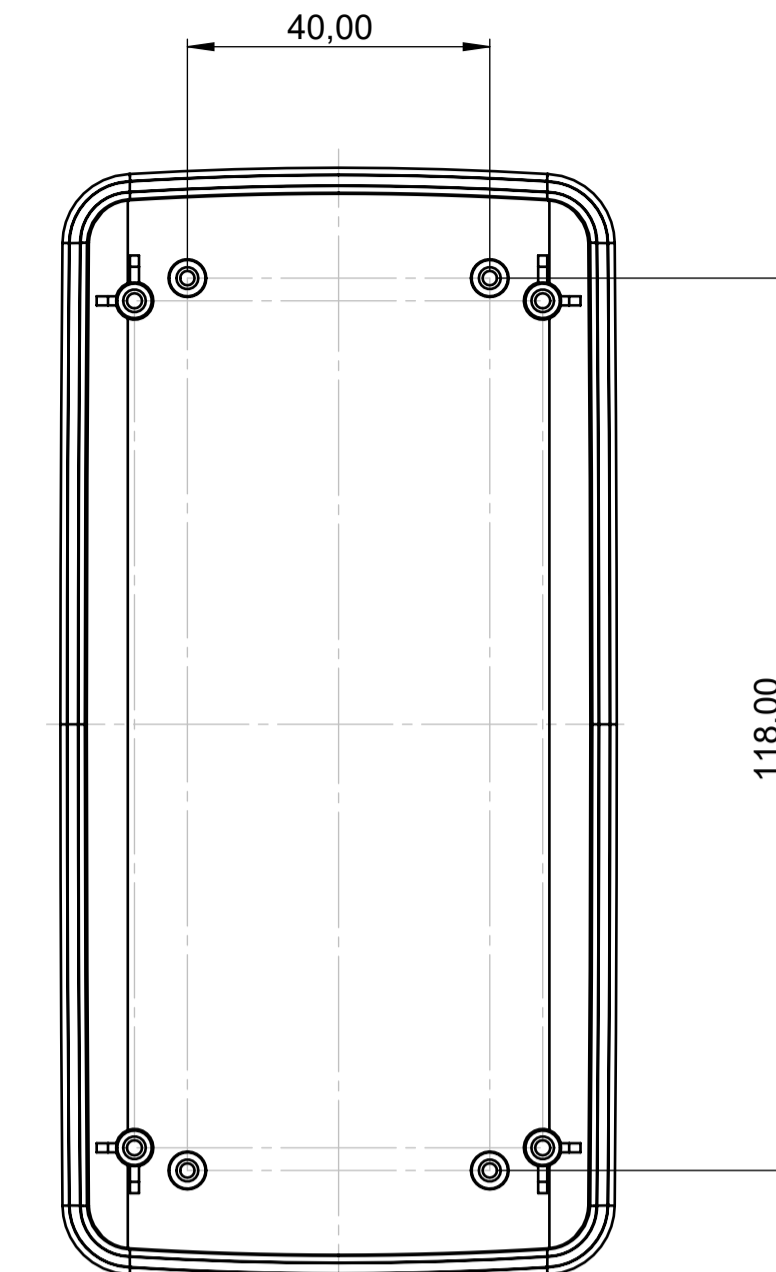

Unterteil
Bottom Part

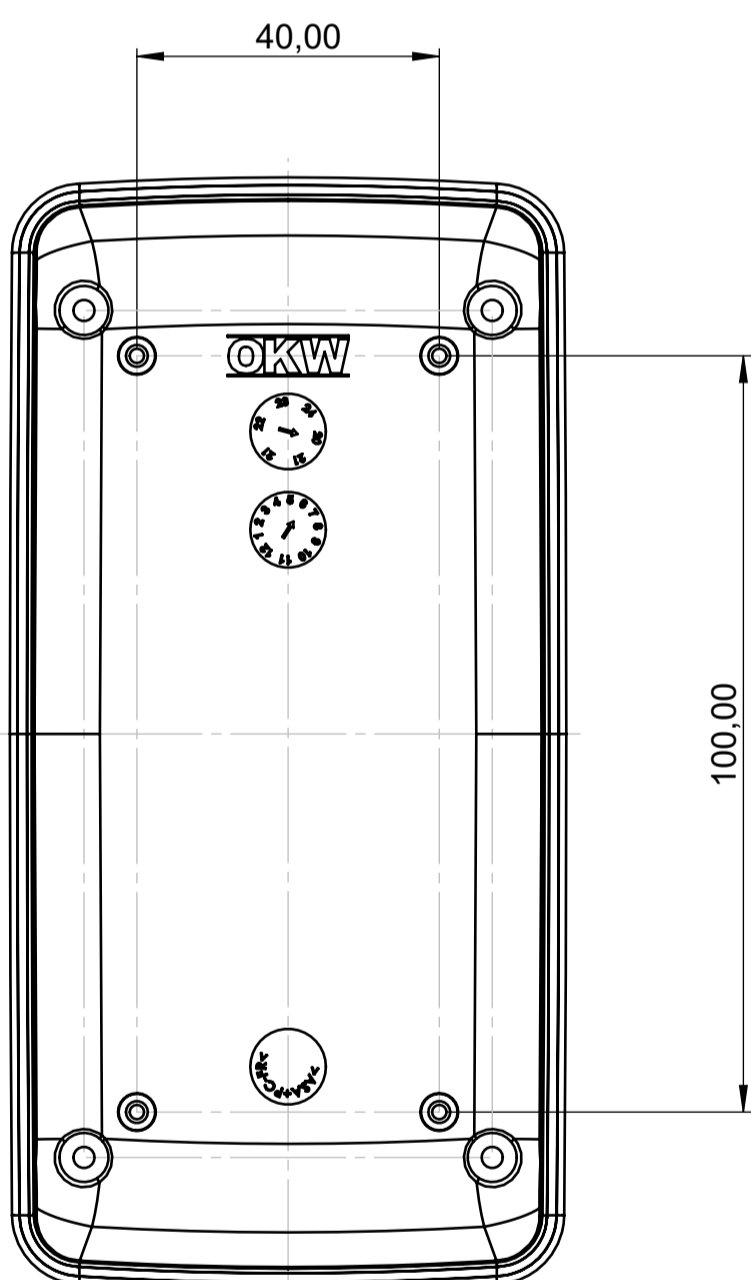

Platine Oberteil
P C B Top Part

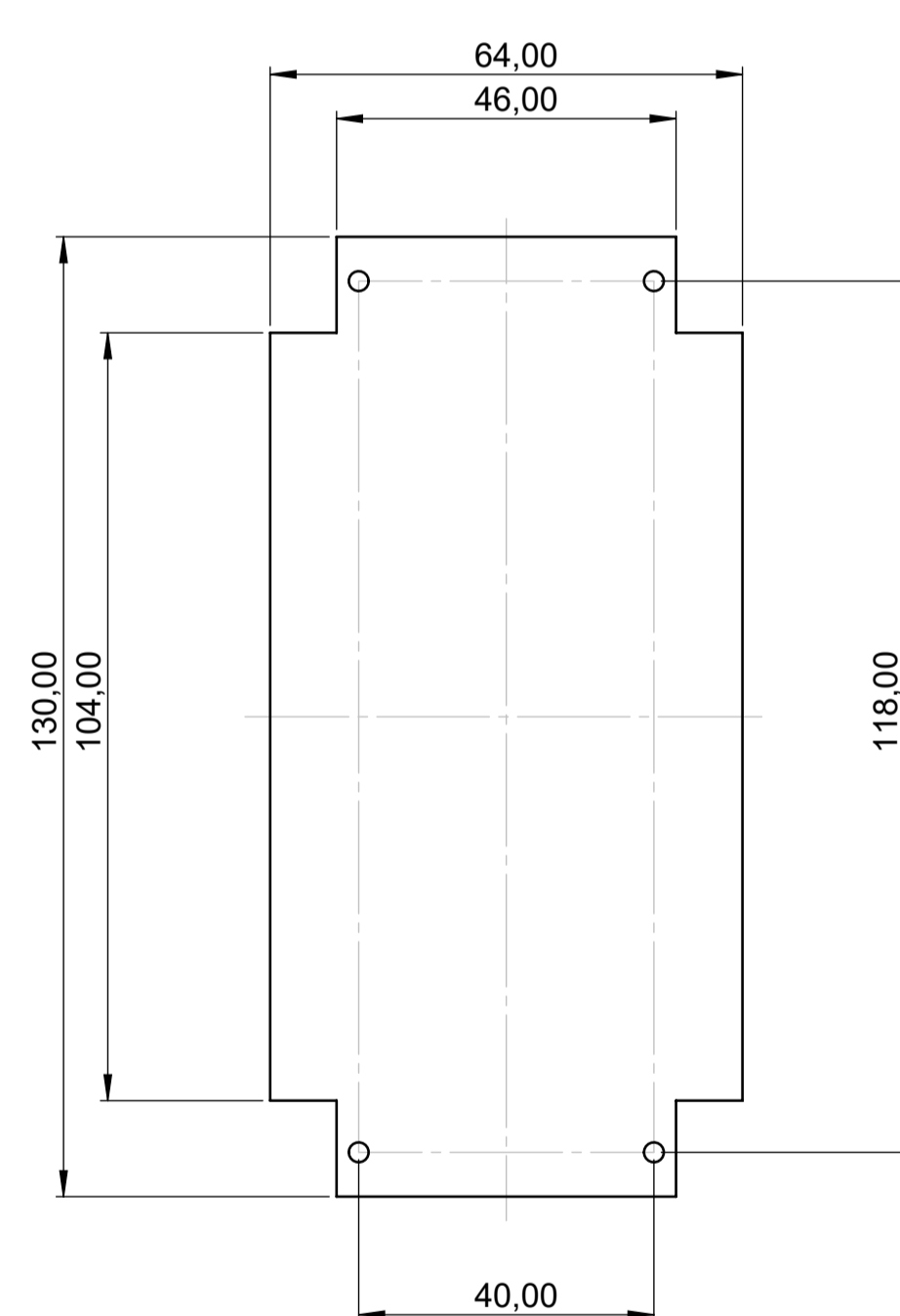

Platine Unterteil
P C B Bottom Part

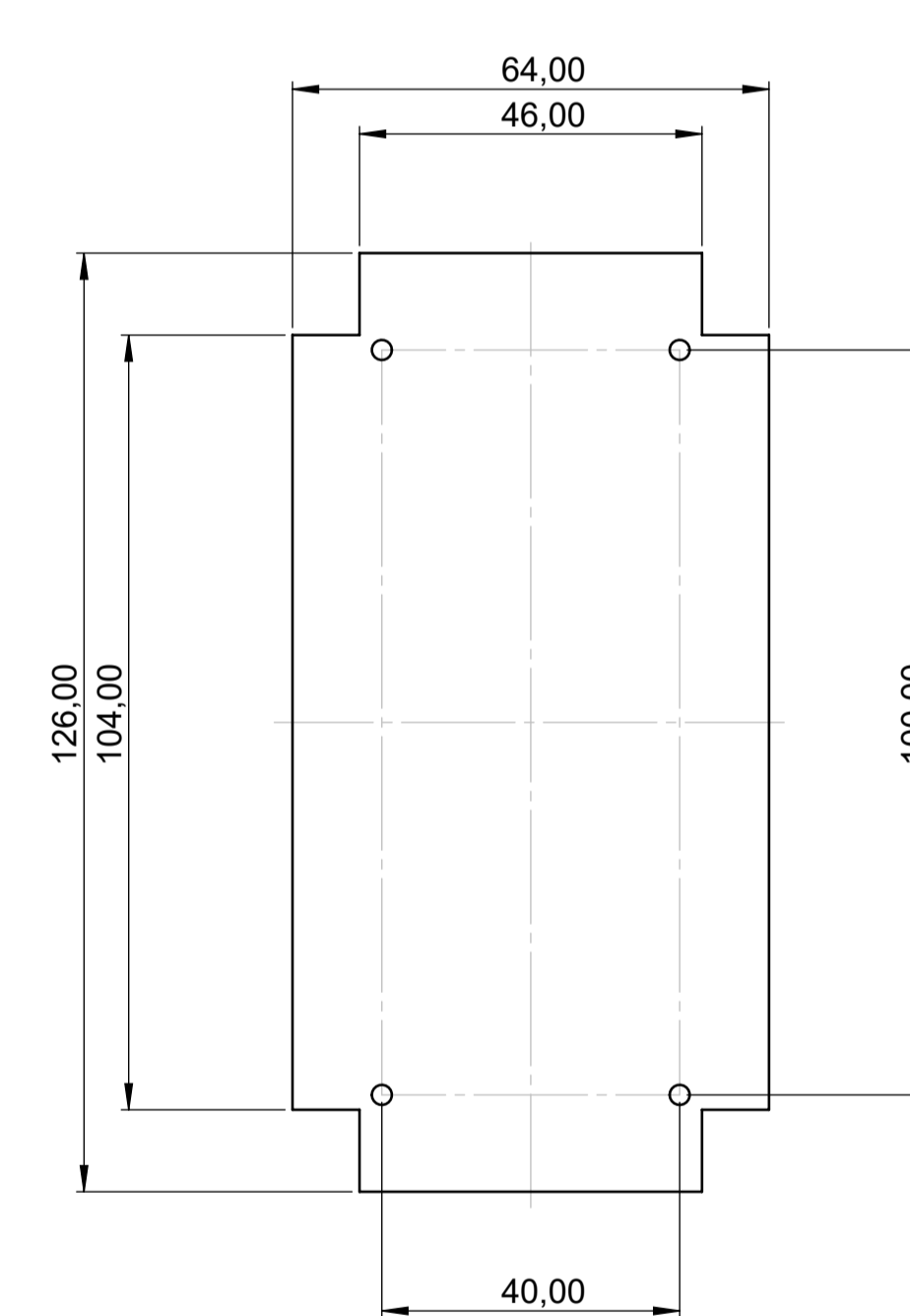

Schnitt B-B

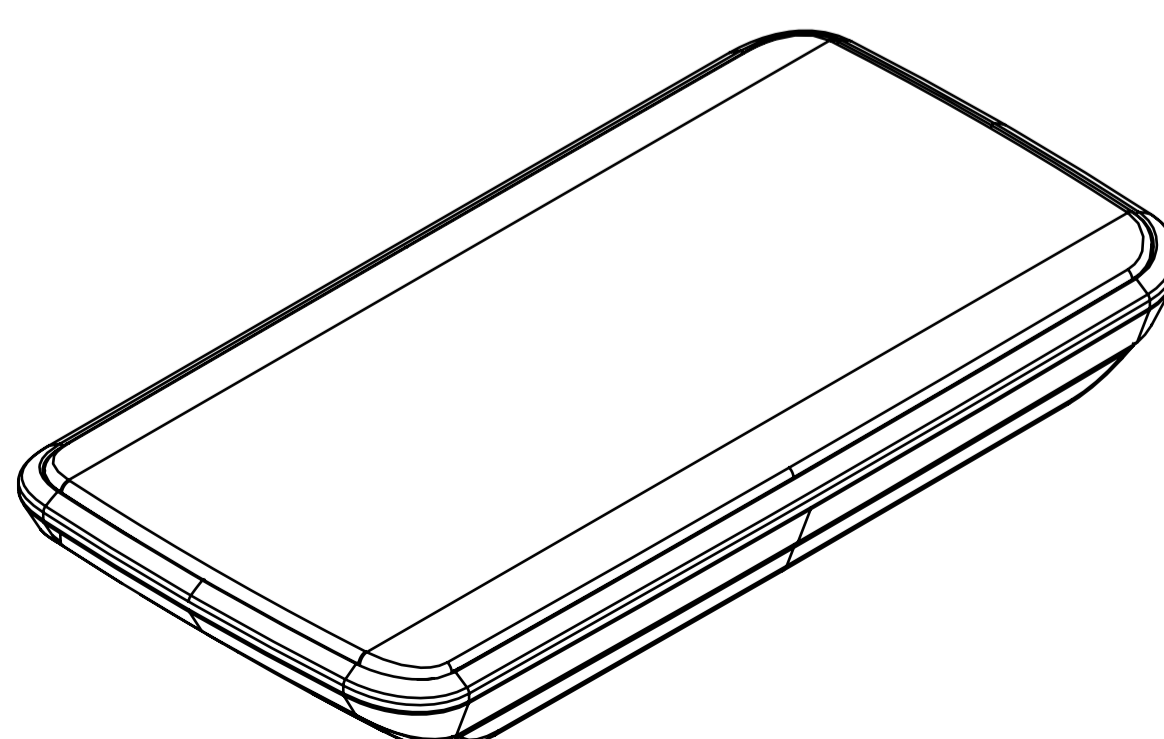
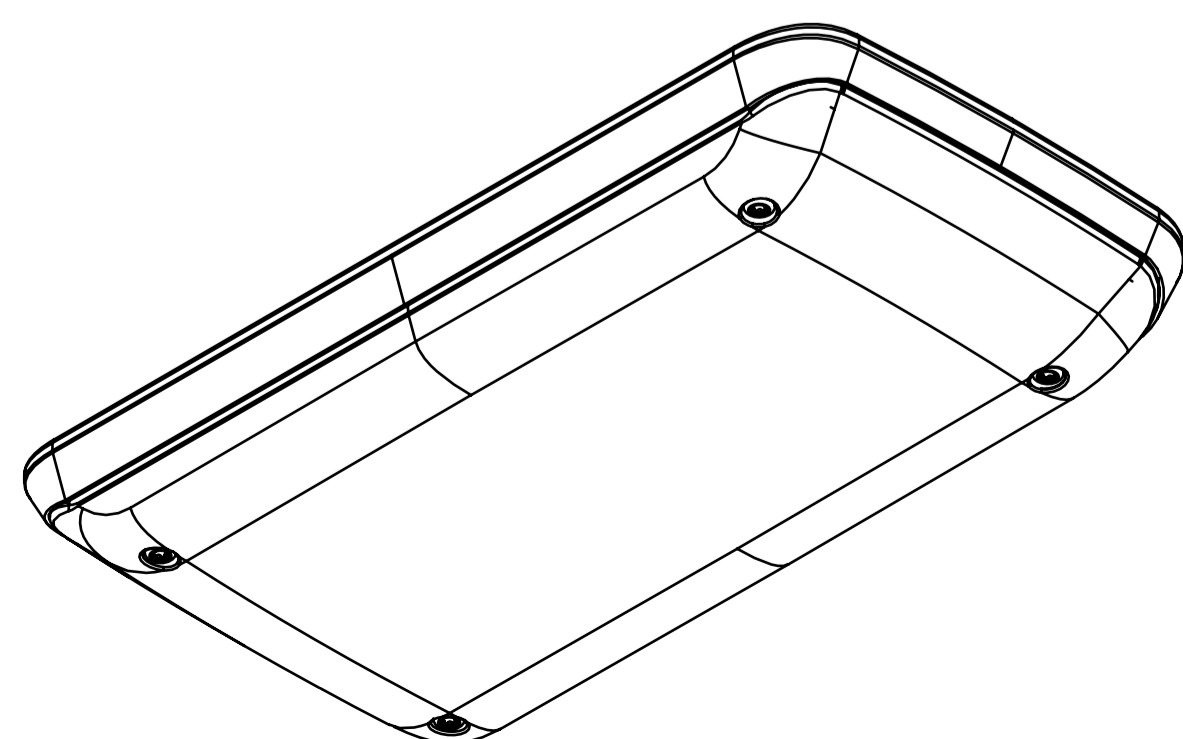
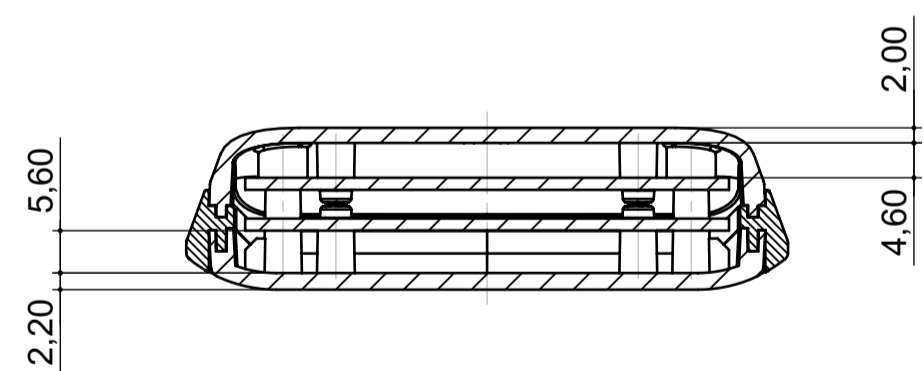

<p>Bitte die Maße an aktuellen Teilen abnehmen. Diese unterliegen material- und produktionsspezifischen Fertigungstoleranzen.</p> <p>Please take the dimensions from current parts. These are subject to material and manufacturing-specific tolerances.</p>	<p>Informationskopie Copy for Information will not be updated</p>	<p>Erst. am: 19.03.2020 Erst. von: O. Herrlich Freig. am: Freig. von: Revision: 01</p>	<p>Toleranzen: DIN 16742 Tg 6 Volumen: Zeichnungsart: KUNDE</p>	<p>Status: ENTWICKLUNG Zeichnungsart: KUNDE</p>	<p>DIN 6 Teil 2</p>
		<p>Technische Änderungen vorbehalten. Interner oder Druckerler begründen keinen Anspruch auf Schadenersatz. Wichtige Einbaumasse bitte direkt mit dem aktuellen Produkt abstimmen. Subject to technical modification without prior notice. Typographical and other errors do not justify any claim for damages. All dimensions should be verified using an actual moulded part. Sous réserve de modifications techniques. Toute erreur ou faute d'impression ne justifie aucune demande d'indemnisation. Veuillez prior les clients de vérifier les dimensions des composants avec les boîtiers avant le montage.</p>		<p>This document contains proprietary information of OKW Gehäusesysteme GmbH and is rendered subject to the conditions that the information be retained in confidence and not be reproduced or copied and not be used or incorporated in any product.</p>	
<p>OKW GEHÄUSE SYSTEME</p>		<p>SLIM-CASE M Ausführung IV B5403110</p>		<p>M 1:1 Dateiname: 00026932</p>	